

TG9 Series

T9908 .02

Dimmer for LED Light 100W (3 wire system) - 1 module Plastic Quartz Gray

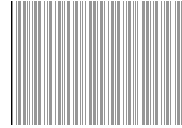
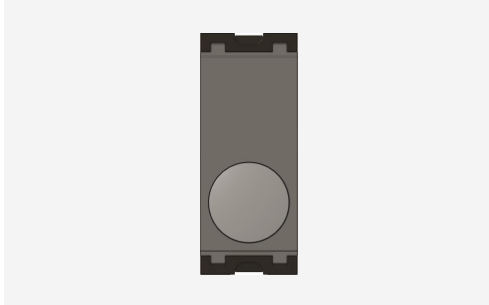

5267.51.8



Code:	T9908 .02
Series:	TG9 Series
Family:	Fan Regulator & Dimmers
Module Size:	One Module
Colour:	Plastic Quartz Gray
Mark:	Norisys
Rated supply voltage:	230V A.C - 50Hz
Maximum load:	100W
Dimensions:	55.6mm x 22.4mm x 60.04mm
Weight:	50.1g

Wiring Diagram:

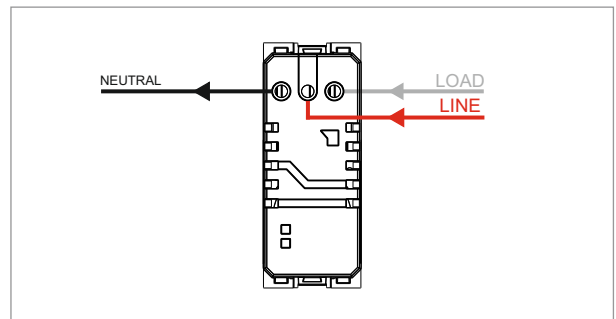

Drawings:

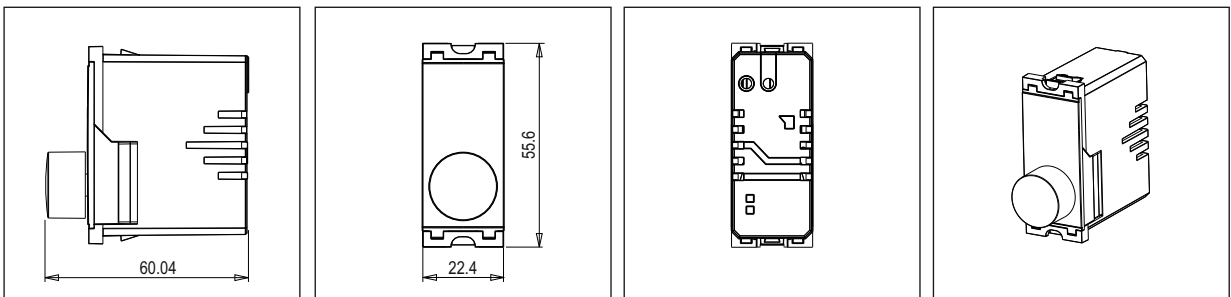

Installation:



Installation of the product should be carried out in compliance with the current regulations regarding the installation of electrical systems in the country where the product is installed.

The product should be installed by a trained professional following all safety norms.

Keep away from water and wet surfaces. While mounting the product, hands should not be wet.