

SQUARE Series

S7723 .23

Shaver Socket 220V/110V with transformer - 2 Module Graphite Gray

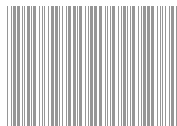
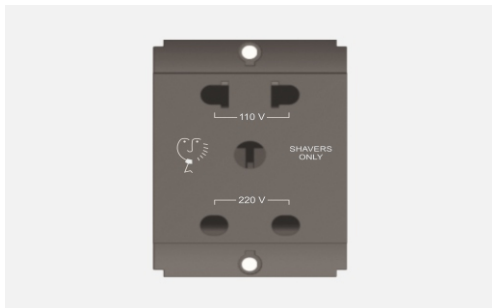

5267.51.8



Code:	S7723 .23
Series:	SQUARE Series
Family:	Hospitality Modules
Module Size:	Two Module
Colour:	Graphite Gray
Mark:	Norisys
Rated supply voltage:	220V/110V
Maximum resistive load:	13A
Dimensions:	48mm x 67.4mm x 33.6mm
Weight:	122.3g

Wiring Diagram:

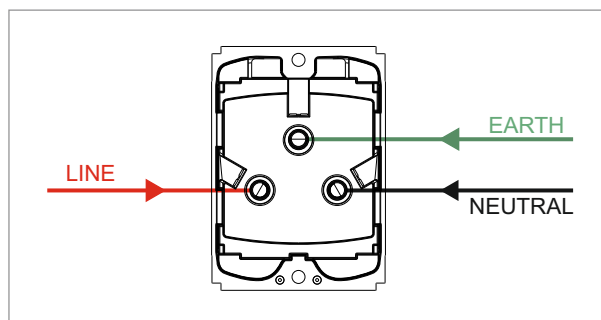

Drawings:

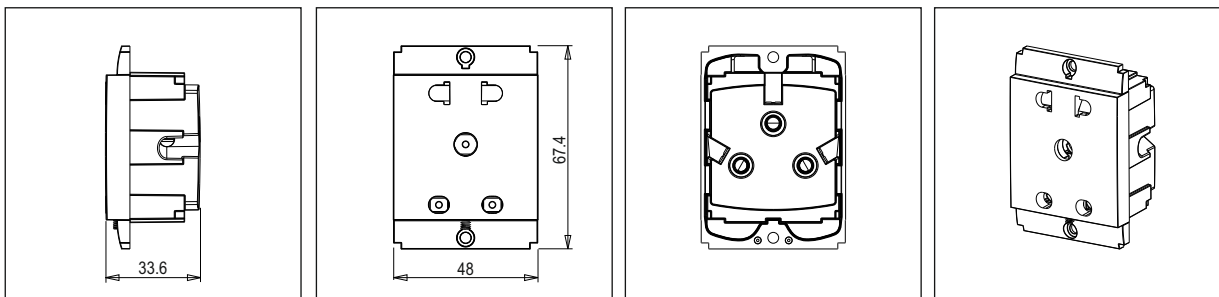

Installation:

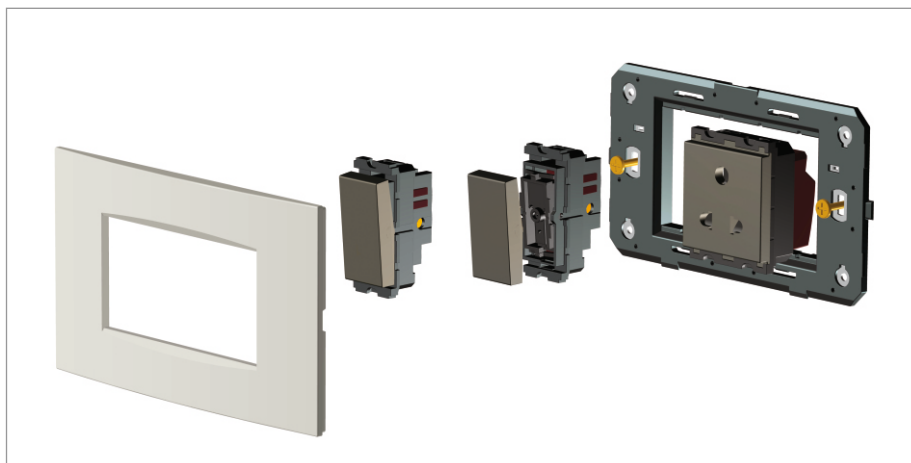

Installation of the product should be carried out in compliance with the current regulations regarding the installation of electrical systems in the country where the product is installed.

The product should be installed by a trained professional following all safety norms.

Keep away from water and wet surfaces. While mounting the product, hands should not be wet.