

**SQUARE Series**

**S7633 .25**

3M Plate Cocoa Brown

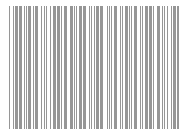
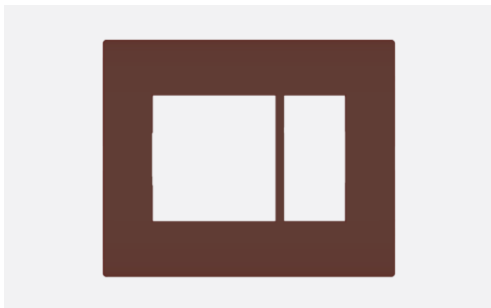

5267.51.8



Code:	S7633 .25
Series:	SQUARE Series
Family:	Smart Plate with frames
Module Size:	Three Module
Colour:	Cocoa Brown
Mark:	Norisys
Rated supply voltage:	--
Maximum resistive load:	--
Dimensions:	114mm x 90.5mm x 16.7mm)
Weight:	62.9g

Wiring Diagram:

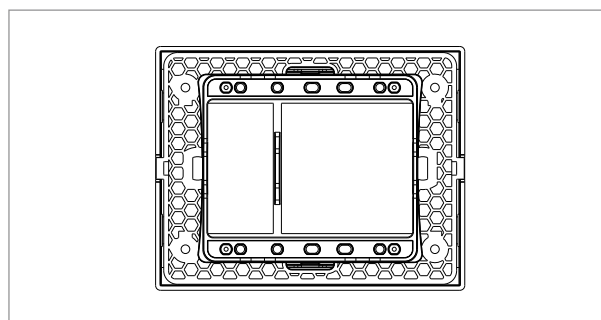

Drawings:

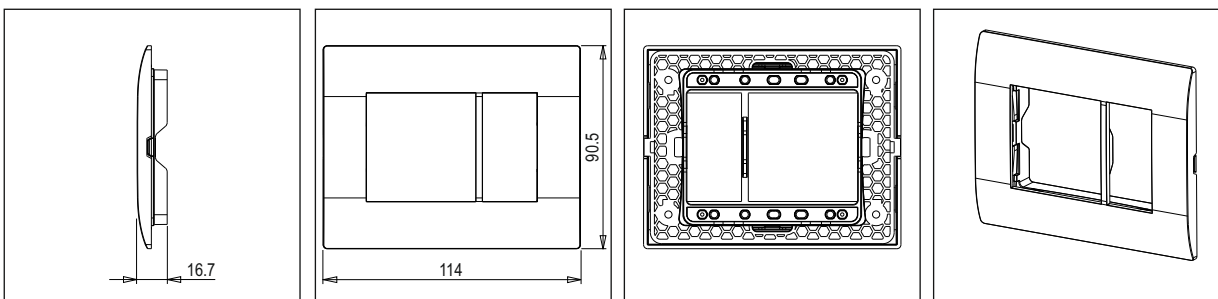

Installation:

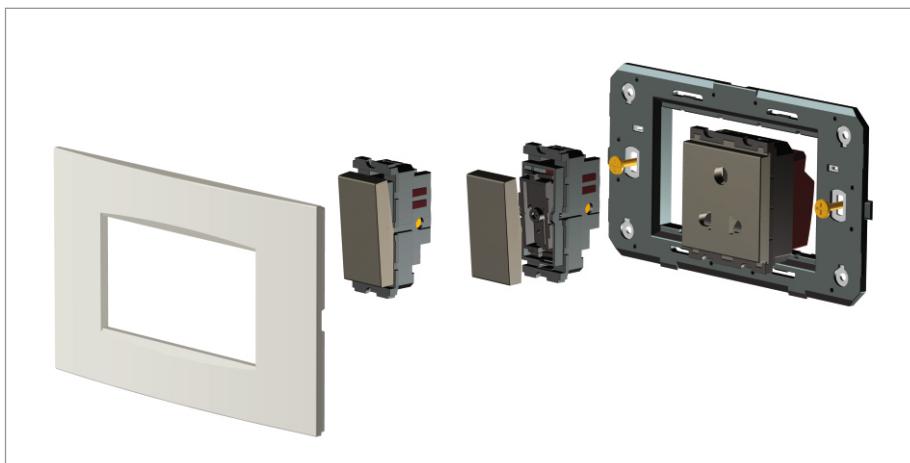

Installation of the product should be carried out in compliance with the current regulations regarding the installation of electrical systems in the country where the product is installed.

The product should be installed by a trained professional following all safety norms.

Keep away from water and wet surfaces. While mounting the product, hands should not be wet.